

SAMBO

Torque Limiter

SB-TL Series

- A torque limiter is an automatic device that controls actuator input torque.
- A torque limiter prevents actuator and valve damage due to over-torque.
- A torque limiter is installed to the gearbox individually to prevent over-torque.
- In the event of a over-torque, a torque limiter permanently separates the drive shaft and the driven shaft.
- Decoupling shafts can be re-engaged manually.
- The installation and maintenance manual (IOM) explains how to install and maintain the SAMBO SB-TL operator and spare parts is provided.

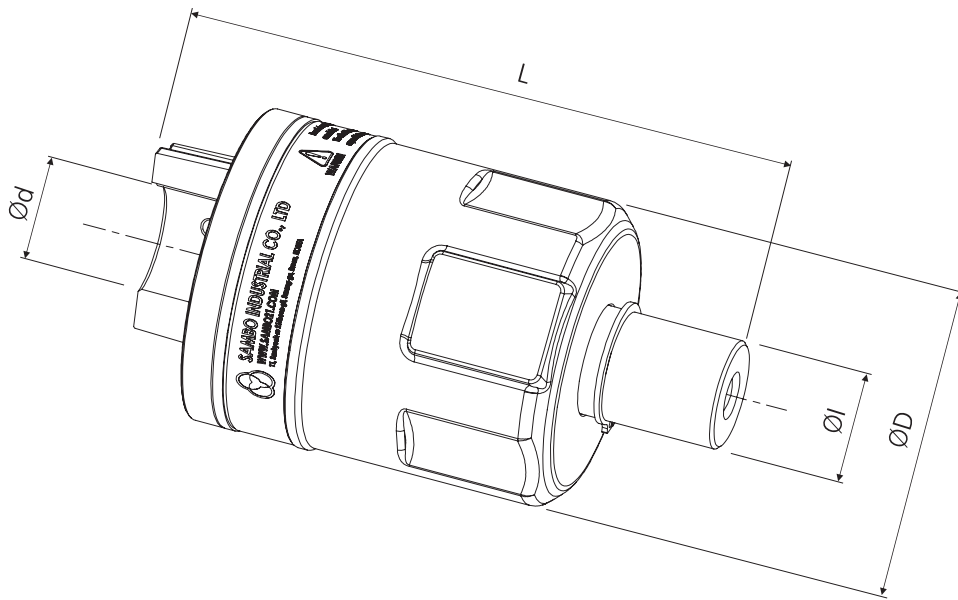

Dimension >>>

MODEL	DIM	External Part		Input	Output
		ØD (mm)	L (mm)	ØI (mm)	Ød (mm)
SB-TL50		60	111	MAX Ø16	MAX Ø16
SB-TL100		81	157	MAX Ø26	MAX Ø26
SB-TL200		90	178	MAX Ø32	MAX Ø38
SB-TL300		102	169	MAX Ø32	MAX Ø38
SB-TL400		117	169	MAX Ø32	MAX Ø38

Size and component specification in this catalogue are subject to change without prior notice for quality improvement.
 * Mark has been changed and updated.

Features >>>

- Water Proof : Standard IP67 grade, Option : IP68 grade
- Different type
 - Automatic Re-engage type. (Standard)
 - Clockwise rotation "Close" manual re-engage type.
 - Counter-Clockwise rotation "Close" manual re-engage type.
- Easy torque limit adjustment.
- Durable and easy maintenance.
- Variety applications. (OPTIONAL)

Installation >>>

- Assemble the key on the valve or reducer input shaft.(PC#2)
- Assemble SB-TL according to key direction.(PC#3)
- Fix SB-TL with set screw.(PC#4)
- Assembly of the handle on the input shaft of SB-TL.(PC#5)

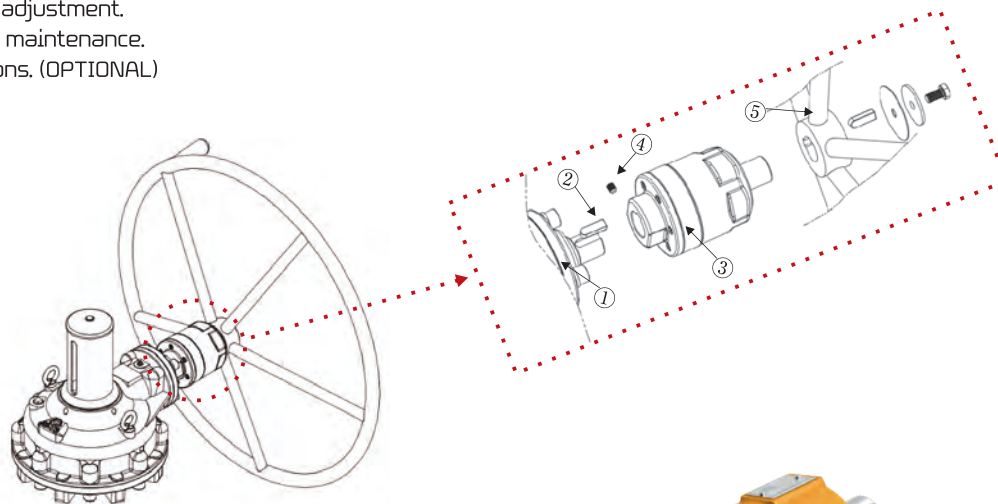

Torque Limiter with SB-V1

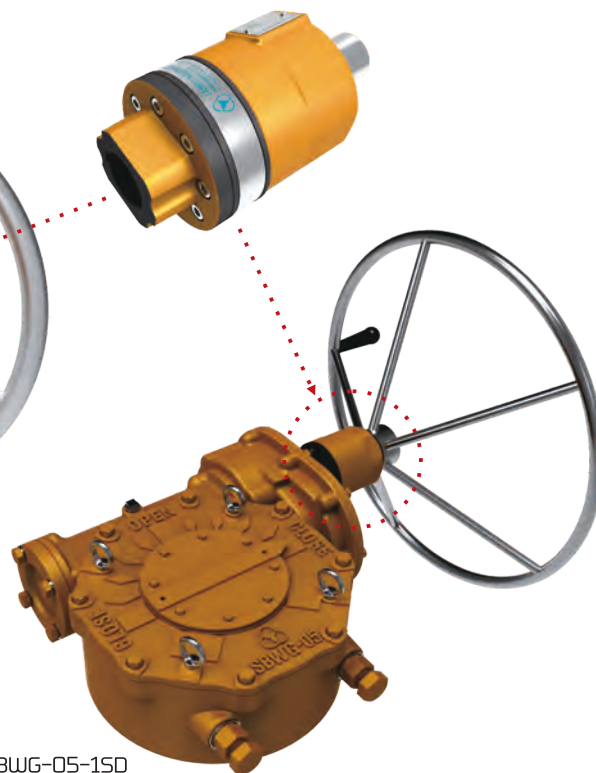

Torque Limiter with SBWG-05-15D

Performance Specifications >>>

MODEL	Torque Range			Consecutive Repeated Trip Torque Fluctuations	Adjustment screw pitch (mm)	Backlash (mm)	Weight (kg)
	(N.m)	(Kgf.m)	(lbf.ft)				
SB-TL50	20~50	2,03~5,1	14,7~36,9	±10%	2,5	Almost None	3,5
SB-TL100	50~100	5,1~10,2	36,9~73,8	±10%	2,5	Almost None	4,0
SB-TL200	100~200	10,2~20,4	73,8~147,5	±10%	2,5	Almost None	4,7
SB-TL300	200~300	20,4~30,6	147,5~221,3	±10%	2,5	Almost None	5,5
SB-TL400	300~400	30,6~40,8	221,3~295,0	±10%	2,5	Almost None	6,5

Size and component specification in this catalogue are subject to change without prior notice for quality improvement.
* Mark has been changed and updated.