

# SAMBO SBWG-S : Subsea Gear Box

New Developed Products.  
Designed for the Most Extreme Deep Sea Applications.

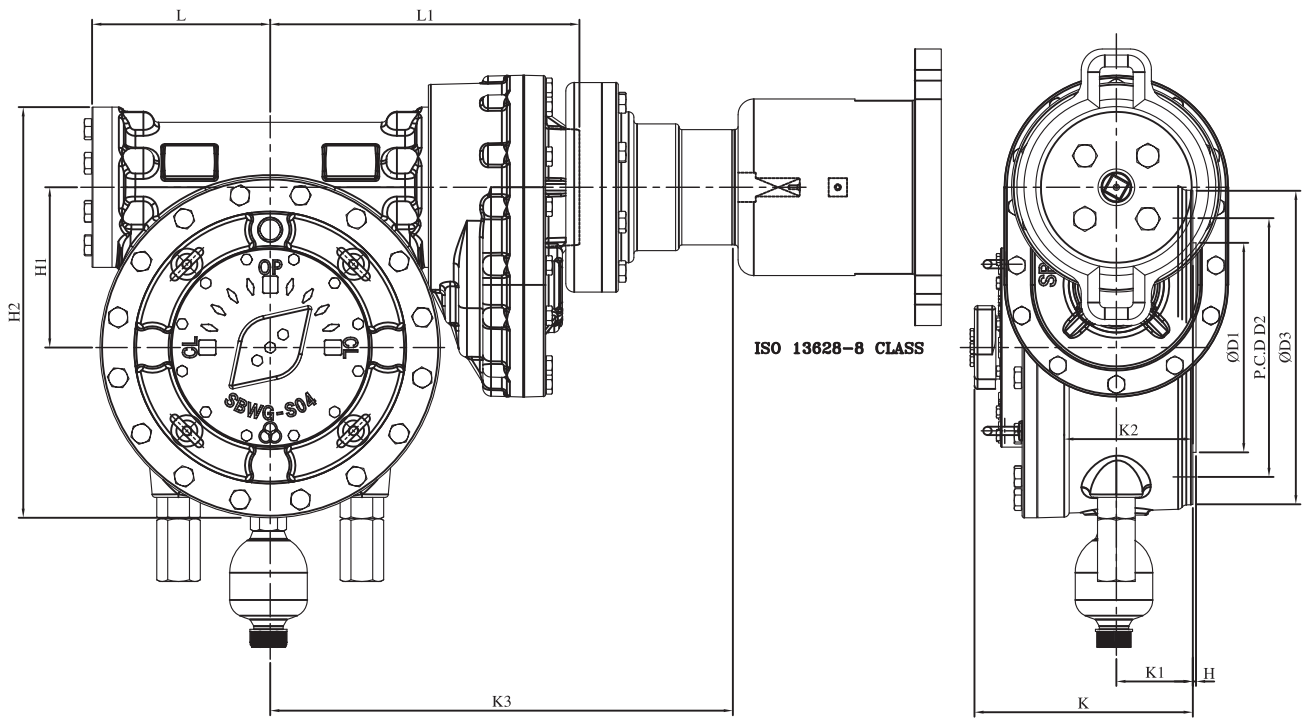

## Dimension >>>

UNIT : mm

DIM MODEL	BASE PART						EXTERNAL PART									INPUT SHAFT PART			HAND WHEEL
	TYPE	FLANGE	ØD1	P.C.D		ØD3	H	H1	H2	K	K1	K2	K3	L	L1	L2	ØPD	KEY	
				ØD2	N-H-DP														
SBWG-S00-1SD	A	F-12	85	125	4-M12-18	165	2	69,5	210	127	43	53,6	283	86	166	29	21	6X6	300
SBWG-S01-1SD		F-14	100	140	4-M16-24	190		82,5	235,5	136	53	65	292	95	175				400
SBWG-S02-1SD		F-16	130	165	4-M20-30	220		97	282	160	56	75,5	345	108	190,5				500
SBWG-S03-1SD	B	F-16 (F-20)	160	205	8-M16-24	250	3	112	312	166	59	87	355	118	200,5	34	26	8X7	560
SBWG-S35-1SD		F-25	200	254	8-M16-24	300		127	352	186	72	100	366	125	218,5				630
SBWG-S04-1SD		F-25	200	254	8-M16-24	300		153	417,5	208	73	120	442	153	250				710
SBWG-S05-1SD		F-30	230	298	8-M20-30	350		180	469,5	225	78	141	452	163	260				800
SBWG-S55-1SD						350		202	516,5	232	80	144	463	183	280				900
SBWG-S06-1SD		F-35	260	356	8-M30-45	415		230	621	280	109	173	523	217	349				800
SBWG-S07-1SD		F-40	300	406	8-M36-55	475		280,5	723	307	116	209	558	252	384				900
SBWG-S75-1SD		C	F-48	370	483	12-M36-55		560	326	860	346	120	220	701	279				485
SBWG-S08-1SD	560						379	968	354	125	245	736	314	520	1000				

Size and component specification in this catalogue are subject to change without prior notice for quality improvement.  
\* Mark has been changed and updated.

ETC.

## Feature >>>

- Quarter-turn Worm gear operators.
- Application of high load input prevention device.
- Applicable to subsea more than 3,000m.
- Using angular contact Taper Roller Bearing.
- Double sealing.
- Self Locking.
- Membrane type pressure compensator.
- Permanent lubrication with eco-compatible oil.
- Many ratios available.
- Horizontal or vertical mounted ROV input from class 1 to 7.

Global Leader  
**SAMBO** SPIRAL BEVEL GEAR ACTUATORS

# The World's Highest Quality!

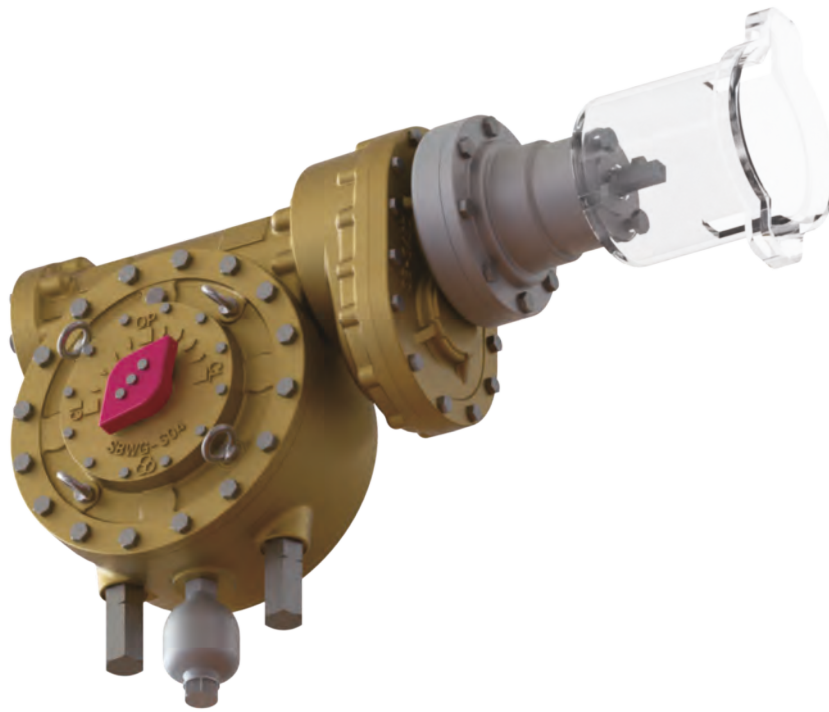

## Selection Chart for Manual Operation >>>

SIZE MODEL	GEAR RATIO	MAX. STEM ACCEPTANCE	BASE MOUNTING OPTION & STANDARD	MAX. TORQUE CAPACITY		WEIGHT
				N-m	Ft. lbf	Kg
SBWG-S00-1SD	160 : 1	36 (10X8)	F-10, F-12	1200	885	25
SBWG-S01-1SD	176 : 1	46 (14X9)	F-10, F-12, F-14	2000	1475	30
SBWG-S02-1SD	308 : 1	60 (18X11)	F-12, F-14, F-16	2800	2065	48
SBWG-S03-1SD	333.7 : 1	75 (20X12)	F-14, F-16, (F-20)	4300	3172	63
SBWG-S35-1SD	333.7 : 1	80 (22X14)	F-16, (F-20), F-25	6100	4499	76
SBWG-S04-1SD	504 : 1	95 (25X14)	F-16, (F-20), F-25	10400	7671	130
SBWG-S05-1SD	540 : 1	115 (32X18)	F-25, F-30	15900	11727	168
SBWG-S55-1SD	558 : 1	125 (32X18)	F-25, F-30	23500	17333	202
SBWG-S06-1SD	1024 : 1	140 (36X20)	F-25, F-30, F-35	32800	24192	338
SBWG-S07-1SD	1088 : 1	180 (45X25)	F-30, F-35, F-40	51100	37689	426
SBWG-S75-1SD	1650 : 1	210 (50X28)	F-35, F-40, F-48	81500	60111	810
SBWG-S08-1SD	1650 : 1	250 (56X32)	F-40, F-48	121000	89245	1031

Size and component specification in this catalogue are subject to change without prior notice for quality improvement.  
 \* Mark has been changed and updated.

ETC.