

USER INSTRUCTIONS

Sambo SB- SR Series

*Installation
Operation
Maintenance*

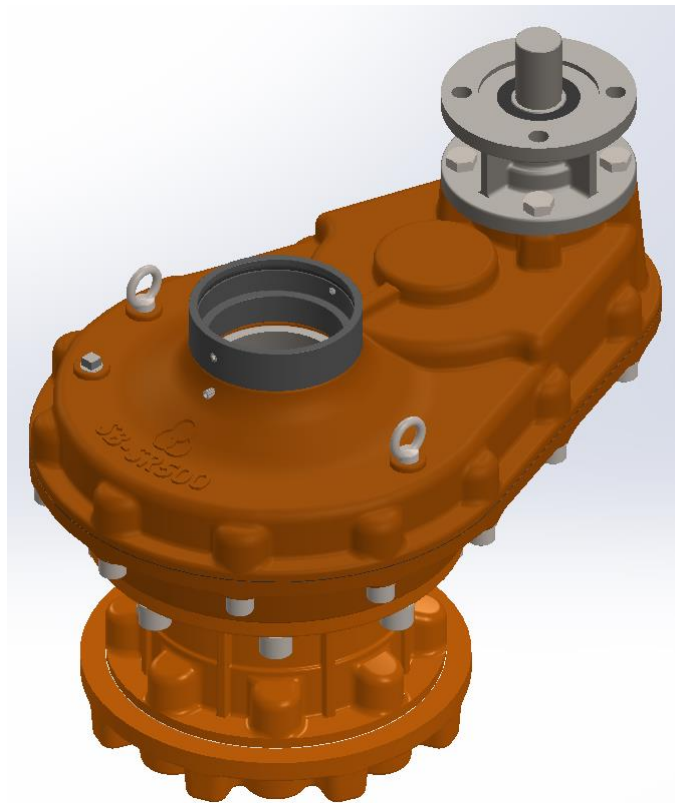

Contents

1 Introduction	3
1.1 Purpose	3
1.2 User Safety	3
2 Inspection, Installation and Mounting Procedures	4
2.1 Initial Inspection and Storage Instructions	5
2.2 Inspection and Recording	5
2.3 Storage Procedure	6
2.4 Safety Precautions	6
2.5 Safety Practices	6
2.6 General Mounting Instructions	6
2.7 Stem Cover Mounting Instructions	8
3 Lubrication	9
4 Product Weights	10
5 Disassembly and Reassembly Instructions	11
5.1 Disassembly and Reassembly of V0 through V9	11
5.2 Disassembly and Reassembly of V35H through V9H	14

Figures

Figure 2.1 – SR Exploded View	4
Figure 2.2 – SRH Exploded View	5
Figure 5.1 – SR50 – SR800 Assembly View	13
Figure 5.2 – SR200H – SR800H Assembly View	16

Tables

Table 3.1 – Lubricants	9
Table 4.1 – SR Gearbox Weights	10
Table 4.2 – SRH Gearbox Weights	10
Table 5.1 – SR50 Through SR800 Parts List	13
Table 5.2 – SR200H Through SR800H Parts List	16

1

Introduction

1.1 Purpose

The installation and maintenance manual (IOM) explains how to install and maintain the Sambo SR series gearbox. Information on installation, disassembly, reassembly, lubrication and product weights is provided.

1.2 User Safety

Safety notices in this manual detail precautions the user must take to reduce the risk of personal injury and damage to the equipment. The user must read and be familiar with these instructions before attempting installation, operation or maintenance. Failure to observe these precautions could result in serious bodily injury, damage to the equipment, voiding of the warranty, or operational difficulty.

Safety notices are presented in this manual in three forms:

- C WARNING:** Refers to personal safety. Alerts the user to potential danger. Failure to follow warning notices could result in personal injury or death.
- a CAUTION:** Directs the user's attention to general precautions that, if not followed, could result in personal injury and/or equipment damage.

NOTE: Highlights information critical to the user's understanding of the SR gearbox's installation and operation.

2

Inspection, Installation and Mounting Procedures

Figure 2.1 - SR Exploded view

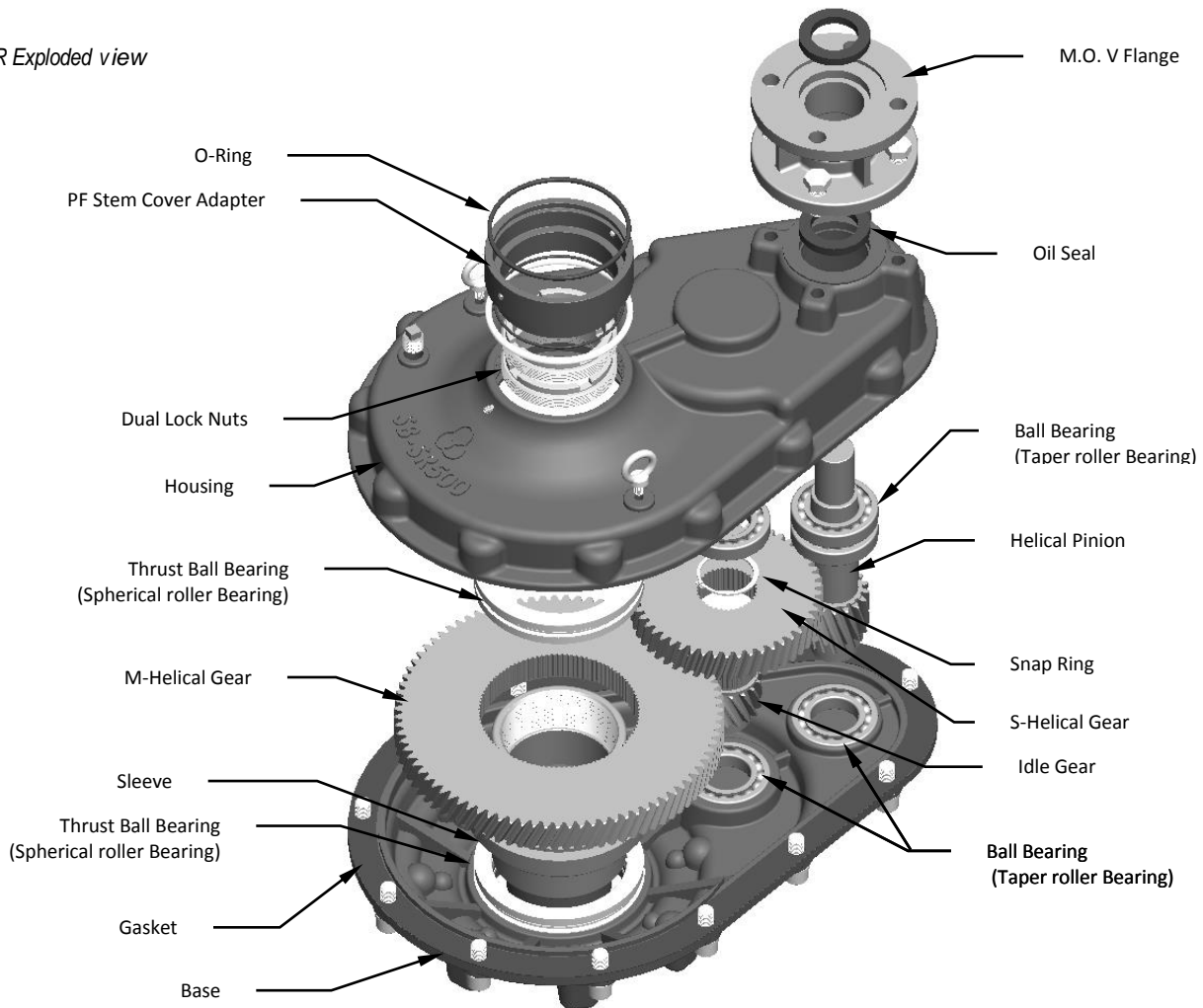

4

C WARNING: Do not manually operate the SR gearbox with devices other than the installed handwheel or wrench nut. Using additive force devices (cheater bars, wheel wrenches, pipe wrenches, or other devices of this nature) on the gearbox handwheel, wrench or wrench nut may cause serious personal injury and/or damage to the gearbox or valve.

Sambo SB-SR series spur gear

Figure 2.2 - SRH Exploded View

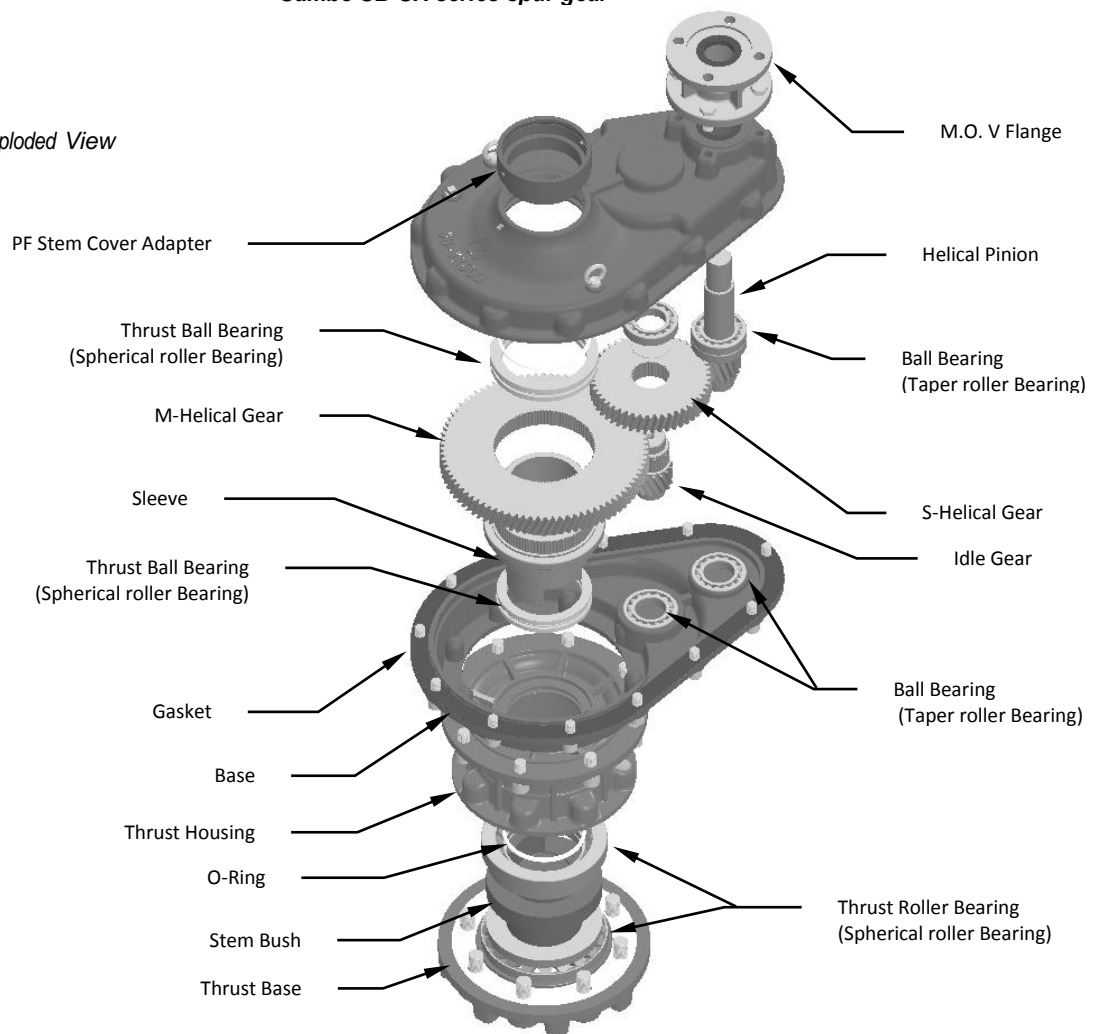

2.1 Initial Inspection and Storage Instructions

C WARNING: Read this installation and maintenance manual carefully and completely before attempting to store the gearbox. If an electric actuator is attached to the SB gearbox, be aware of the electrical hazards. Consult the electric actuator installation and maintenance manual for guidance.

2.2 Inspection and Recording

Upon receipt of the gearbox, inspect the condition of the equipment, and record nameplate information.

1. Carefully remove the gearbox from the shipping carton or skid. Thoroughly examine the equipment for any physical damage that may have occurred during shipment. If damaged, immediately report the damage to the transport company.
2. A nameplate is attached to each gearbox with the following information:
 - Gearbox size
 - Order number
 - Serial number
 - Customer tagging

Record this information for future reference, e.g., ordering parts, or obtaining further information.

2.3 Storage Procedure

NOTE: The following is the recommended storage procedure to retain maximum product integrity during storage. Failure to comply with recommended procedure will void the warranty.

Storage (less than one year)

Store the gearboxes on wooden skids to protect the machined mounting flange. Place the wooden skids containing the gearboxes in a clean, dry, protected warehouse. If the gearboxes must be stored outside, they must be covered in polyethylene protection with silica gel crystals to absorb moisture. If an electric actuator is attached to the V gearbox, refer to the storage procedures in its respective manual for appropriate storage procedures. Rotate input shafts every three months to mix the lubricant.

2.4 Safety Precautions

- C WARNING:** Read this Installation, Operation and Maintenance manual carefully and completely before attempting to install, operate or troubleshoot the SAMBO gearbox.
- C WARNING:** Potential HIGH-PRESSURE vessel — be aware of high-pressure hazards associated with the attached valve or other actuated device when installing or performing maintenance on the gearbox. Do not remove the gearbox mounting bolts from the valve or actuated device unless the valve or device stem is secured or there is no pressure in the line.
- C WARNING:** For maintenance and/or disassembly of the gearbox while installed on the valve, ensure that the gearbox is not under thrust or torque load. If the valve must be left in service, the valve stem must be locked in such a way as to prevent any movement of the valve stem.
- C WARNING:** Do not manually operate the gearbox with devices other than the installed handwheel. Using force beyond the ratings of the gearbox and/or using additive force devices such as cheater bars, wheel wrenches, pipe wrenches, or other devices on the gearbox handwheel may cause serious personal injury and/or damage to the gearbox and valve.
- C WARNING:** Do not exceed any design limitations or make modifications to this equipment without first consulting SAMBO.
- C WARNING:** Use of this product must be suspended any time it fails to operate properly.
- a CAUTION:** If a motor actuator is driving the gearbox, do not operate the valve under motor operation without first checking and setting the limit switch and checking for correct motor rotation.
- a CAUTION:** Do not use replacement parts that are not genuine SAMBO parts, as serious personal injury and/or damage to the gearbox and valve may result.

2.5 Safety Practices

The following checkpoints should be performed to maintain safe operation of the SAMBO gearbox:

- Set up a periodic operating schedule on infrequently used valves.
- Ensure that the limit and/or torque switches on any electric actuator fitted to the V gearbox are correctly and appropriately adjusted.

2.6 General Mounting Instructions

The mounting instructions for the SB bevel gearboxes are outlined below. The V0 through V9 gearboxes are designed with a splined top-entry Stem Nut which is retained in the Drive Sleeve by two Lock Nuts.

- 6** The SR200H through SR800H gearboxes are designed with a Stem Nut which is retained by two Thrust Roller Bearings within the Thrust Housing and Thrust Base. Partial disassembly of the Thrust Base is required for Stem Nut removal and/or installation.

2.6.1 Installing a Gearbox with a Threaded Stem Nut – SR50 through SR800 and SR200H through SR800H

1. Position the gearbox above the valve stem.
2. Rotate the gearbox handwheel or wrench nut several turns until there is positive engagement between the valve stem and the gearbox Stem Nut.
3. Rotate the handwheel to lower the gearbox onto the valve until contact has been made with the valve flange.
4. Bolt the gearbox securely to the valve mounting flange.

2.6.2 Installing a Gearbox with a Blank Stem Nut – SR50 through SR800

1. Remove the two threaded Lock Nuts (pc# 27) from the Drive Sleeve (pc# 10), accessed through the top of the Housing (pc# 1).
2. Remove the Stem Nut (pc# 26) from the Drive Sleeve (pc# 10) through the top of the Housing (pc# 1).
3. Machine the Stem Nut (pc# 26) to suit the valve stem.
a CAUTION: Care must be taken to ensure that the clamping devices used during machining do not damage splined surfaces of the Stem Nut.
4. Reinstall the Stem Nut (pc# 26) into the Drive Sleeve (pc# 10), ensuring the splines are properly engaged.
5. Reinstall the two threaded Lock Nuts (pc# 27) into the Drive Sleeve (pc# 10).
6. Mount the gearbox on the valve as detailed in Section 2.6.1 Installing a Gearbox with a Threaded Stem Nut.

2.6.3 Installing a Gearbox with a Blank Stem – SR200H through SR800H

1. Place the gearbox upside down to access the mounting base.
2. Remove the Socket Head Cap Screws (pc# 20) which mount the Thrust Base (pc# 31) to the Thrust Housing (pc# 2).
3. Remove the Thrust Base (pc# 30) and Gasket (pc# 28) from the Thrust Housing (pc# 21).
a CAUTION: Care must be taken to ensure that the O-ring (pc# 29) located in the Thrust Base (pc# 30) is not damaged during disassembly.
4. Remove the Stem Nut (pc# 26) and lower Thrust Roller Bearing (pc# 27).
5. Remove the upper Thrust Roller Bearing (pc# 25). Place all bearings in a clean, dry area until reassembly.
6. Machine the Stem Nut (pc# 26) to suit the valve stem.
a CAUTION: Care must be taken to ensure that the clamping devices used during machining do not damage splined surfaces of the Stem Nut (pc# 26).
7. Reinstall the upper Thrust Roller Bearing (pc# 25) into the Thrust Housing (pc# 21).
8. Install the Stem Nut (pc# 26) into the Thrust Housing (pc# 21) and upper Thrust Roller Bearing (pc# 25).
9. Install the lower Thrust Roller Bearing (pc# 27) onto the Stem Nut (pc# 26).
10. Place the Gasket (pc# 20) onto the Thrust Housing (pc# 21).
11. Separately, install the O-Ring (pc# 29) in the Thrust Base (pc# 30).

Sambo SB series bevel gear operator

12. Install the Thrust Base (pc# 30) with O-Ring (pc# 29) onto the Thrust Housing (pc# 21) and Stem Nut (pc# 26), using Socket Head Cap Screws (pc# 31).

a CAUTION: Care must be taken to ensure that the O-ring (pc# 29) located in the Thrust Base (pc# 30) is not damaged during installation.

13. Mount the gearbox on the valve as detailed in Section 2.6.1 Installing a Gearbox with a Threaded Stem Nut.

2.7 Stem Cover Mounting Instructions

The gearbox is supplied with a Stem Cover Adapter (pc# 38) which accepts unthreaded Stem Covers of standard NPS pipe sizes. Optionally, the adapter may be removed to access PF (BSPP) pipe threads, if required.

2.7.1 Installing an unthreaded Stem Cover using the supplied Stem Cover Adapter

a CAUTION: Care must be taken to ensure the Stem Cover does not damage the O-ring during installation.

NOTE: Lubricate the O-ring (pc# 40) before installing the Stem Cover.

1. Loosen the quantity (4) set screws (pc# 41) in the Stem Cover Adapter (pc# 38).
2. Install the Stem Cover into the Stem Cover Adapter (pc# 38) and secure using the quantity (4) set screws.

2.7.2 Installing a threaded Stem Cover using the optional PF (BSPP) pipe threads

a CAUTION: Care must be taken during installation to prevent damage to the Stem Cover and Housing threads.

NOTE: Apply thread sealant to external threads on Stem Cover before installing.

1. Loosen the set screw (pc# 35) in the Housing (pc# 1).
2. Remove the Stem Cover Adapter (pc# 38) with O-ring (pc# 40) by unthreading it from the Housing (pc# 1).
3. Remove and discard the O-ring (pc# 39).
4. Install the threaded Stem Cover into the Housing (pc# 1) and tighten.

3 Lubrication

SAMBO SB-SR gearboxes are shipped with the following lubricants:

Table 3.1 – Lubricants

Product	Lubricant	Soap Base	Temperature Range
SR50 through SR800	Zenith EPSB-2	Calcium	-20°C to 200°C
SR200H through SR800H	Zenith EPSB-2	Calcium	-20°C to 200°C

NOTE: The lubricant should be checked every 12 months for gearboxes.

CAUTION: Do not add a different lubricant to a SAMBO gearbox unless it is of the same soap base as the existing lubricant, or you have received the approval of the lubricant manufacturer.

Quantity

SAMBO gearboxes are built to operate on the partial immersion principle. The primary concern regarding the amount of lubricant is whether the bevel gear assembly is totally immersed in grease. This can be verified by the use of one or more of the “fill” and “drain” plugs provided on the gearbox housing in most sizes.

Quality

When removing a “fill” or “drain” plug to inspect the lubricant level, remove a small amount and ensure that it is clean and free of any contaminant, including water. Should dirt, water or other foreign matter be found, the gearboxes should be flushed with a commercial degreaser/cleaner which is non-corrosive and does not affect seal materials such as Buna-N or Viton. Repack the gearbox with fresh lubricant.

Consistency

The main gearbox lubricant should be slightly fluid, approximating a standard NLGI-2 grade consistency or less.

Alternate lubricants may be used in place of the standard lubricants supplied by Flowserve, provided they are of a formulation similar to those listed above for the respective product.

4 Product Weights

Table 4.1 - SB-SR Gearbox Weights

MODEL	lbs	kg
SB-SR50	35	16
SB-SR100	77	35
SB-SR200	106	48
SB-SR300	154	70
SB-SR400	291	132
SB-SR500	485	220
SB-SR600	716	325
SB-SR700	987	448
SB-SR800	1389	630

Table 4.2 - SB-SRH Gearbox Weights

MODEL	lbs	kg
SB-SR200H	172	78
SB-SR300H	278	126
SB-SR400H	414	188
SB-SR500H	727	330
SB-SR600H	1045	474
SB-SR700H	1565	710
SB-SR800H	2191	994

5

Disassembly and Reassembly Instructions

C WARNING: See Section 2.4 Safety Precautions and 2.5 Safety Practices before undertaking the steps below.

5.1 Disassembly and Reassembly of SR50 through SR800

Disassembly Instructions

Refer to Figure 5.1

1. Remove the two threaded Lock Nuts (pc# 27) from the Drive Sleeve (pc# 10), accessed through the top of the Housing (pc# 1).
2. Remove the Stem Nut (pc# 26) from the Drive Sleeve through the top of the Housing (pc# 1).
3. Remove the Stem Cover Adapter (pc# 28) and O-Rings (pc# 29 and pc# 30).
4. Remove Bearings (pc# 6 and pc# 14) from the Helical Pinion (pc# 12).
5. Place the gearbox upside down to access the mounting base.
6. Remove the Thrust Base (pc# 17) with O-Ring (pc# 18) and Gasket (pc# 16) by removing Socket Head Cap Screws (pc# 20).
7. Remove the lower Thrust Ball Bearing (pc# 15).
8. Remove the assembled Drive Sleeve (pc# 10) and Helical Gear (pc# 11).
9. Separately, remove the Helical Gear (pc# 11) from the Drive Sleeve (pc# 10).

Sambo SB-SR series spur gear

10. Remove the Input Flange (pc# 32) with Oil Seal (pc# 33) and Gasket (pc# 2)
11. Remove the Helical Pinion subassembly from the Housing (pc# 1).
12. Remove the upper Thrust Ball Bearing (pc# 4) from the Housing (pc# 1).
13. Remove the O-Ring (pc# 15) from the Housing (pc# 3).

Reassembly Instructions

Refer to Figure 5.1

1. Place the Housing (pc# 1) upside down for internal access.
 2. Install the O-Ring (pc# 3) in the Housing (pc# 1).
- NOTE:** Lubricate all O-Rings before installation
3. Install the upper Thrust Bearing (pc# 4) in the Housing (pc# 1).
 4. Separately, install the Helical Gear (pc# 11) onto the Drive Sleeve (pc# 10), engaging the Helical Gear and Drive Sleeve lugs.
 5. Install the assembled Helical Gear (pc# 11) and Drive Sleeve (pc# 10) into the Housing (pc# 1) and Thrust Bearing (pc# 4).
 6. Install the lower Thrust Bearing (pc# 15) onto the Drive Sleeve (pc# 10).
 7. Install the Bearing (pc# 13 and pc# 5) at Housing and Base.
 8. Install the Idle gear (pc# 7) and Helical gear (pc# 8) after That put Snap ring (pc# 9)
 9. Install the Helical Pinion (pc# 12) subassembly into the Housing (pc# 1).
 10. Replace the Oil Seal (pc# 2 and pc# 33) in the Input Flange (pc# 32), if required.
 11. Relace the Gasket (pc# 16) onto the Housing (pc# 1).
 12. Separately, install the O-Ring (pc# 18) in the Thrust Base (pc# 17).

NOTE: Lubricate all O-Rings before installation

13. Install the Thrust Base (pc# 17) with O-Ring (pc# 18) onto the Housing (pc# 1) and Drive Sleeve (pc# 10) using Socket Head Cap Screws (pc# 20).

a CAUTION: Care must be taken to ensure that the O-ring located in the Thrust Base is not damaged during installation.

14. Place the gearbox in the upright position.
15. Install the Stem Cover Adapter (pc# 28) and O-Rings (pc# 29 and pc# 30) on the Housing (pc# 1).

a CAUTION: For proper backlash of the Helical gear set, ensure supplied gaskets and shims (if applicable) are placed between Base (or Spur Gear Attachment) and Housing.

NOTE: Ensure binding does not occur between the Helical Pinion and Helical Gear

NOTE: Lubricate all Oil Seals before installation

Sambo SB-SR series spur gear

Figure 5.1 - SR50,100,200,300,400,500,600,700,-SR800 Assembly View

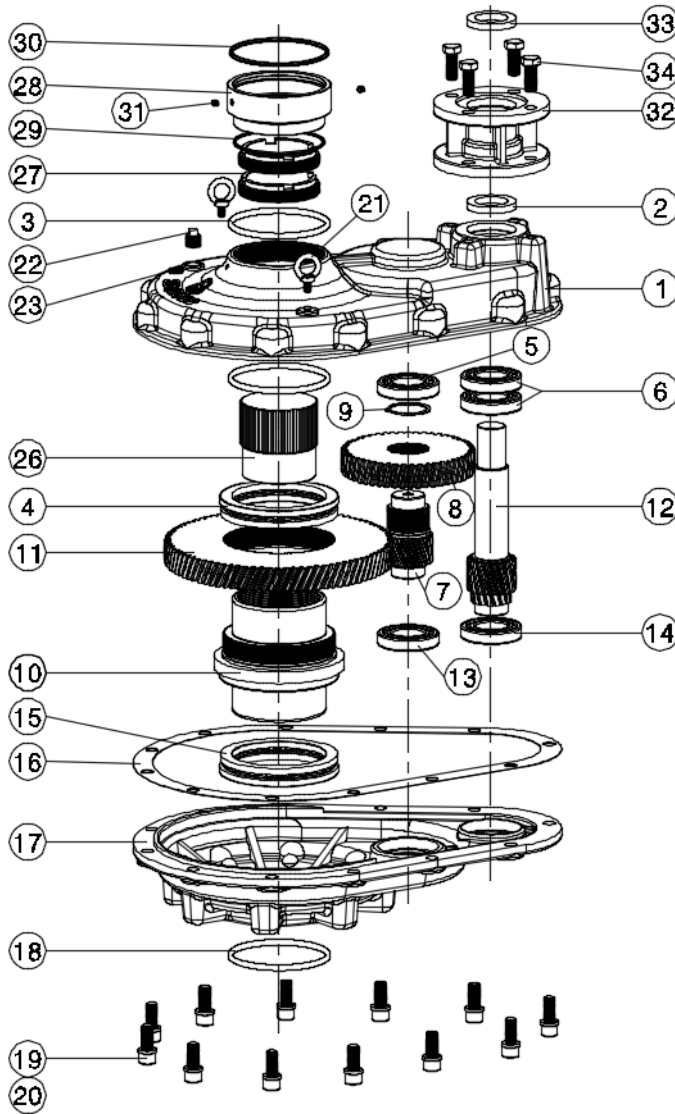
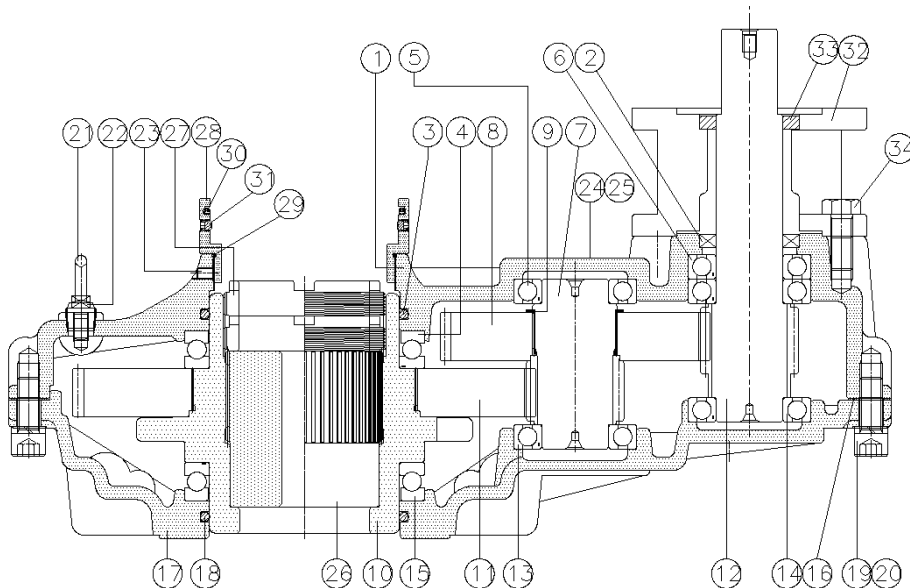

Table 5.1 - SR50 Through SR800 Parts List

Item No.	Description	REMARK
1	HOUSING	
2	OIL SEAL	
3	ORING for HOUSING	
4	THRUST BALL B/R	
5	BALL BEARING for IDLE GEAR	
6	BALL BEARING for H/PINION	
7	IDLE GEAR	
8	S-HELICAL GEAR	
9	SNAP RING	
10	SLEEVE	
11	M-HELICAL GEAR	
12	HELICAL PINION	
13	BALL BEARING for IDLE GEAR	
14	BALL BEARING for H/PINION	
15	THRUST BALL B/R	
16	GASKET for BASE	
17	BASE	
18	ORING for BASE	
19	WASHER_SPRING	
20	WRENCH BOLT	
21	EYE BOLT	
22	PLUG SQ-HEAD	
23	SET SCREW	
24	NAME PLATE	
25	RIVET	
26	STEM BUSH	
27	DUAL LOCK NUTS	
28	PF ADAPTER	
29	O-RING	
30	O-RING	
31	SET SCREW	
32	M.O.V. FLANGE	
33	OIL SEAL	
34	HEX.BOLT	



5.2 Disassembly and Reassembly of SR50H through SR800H

Disassembly Instructions

Refer to Figure 5.2

1. Remove the Stem Cover Adapter (pc# 38) and O-Rings (pc# 39 and pc# 40).
2. Remove the Input Flange (pc# 42) with Oil Seal (pc# 43 and pc# 2) by removing Socket Head hex Screws (pc# 44).
3. Place the gearbox upside down to access the mounting base.
4. Remove the Socket Head Cap Screws (pc# 31), Thrust Base (pc# 30) and Gasket (pc# 28) from the Thrust Housing (pc# 21).
5. Remove the Stem nut (pc# 26) with upper and lower Thrust Roller Bearings (pc# 25 and pc# 27).
6. Remove the Thrust Housing (pc# 21) with O-Ring (pc# 22) and Gasket (pc# 20) by removing Socket Head Cap Screws (pc# 23).
7. Remove the Base (pc# 17) and Gasket (pc# 20) by removing Socket Head Cap Screws (pc# 19).
8. Remove the lower Thrust Ball Bearing (pc# 13-B).
9. Remove the assembled Drive Sleeve (pc# 10) and Helical Gear (pc# 11).
10. Separately, remove the Helical Gear (pc# 11) from the Drive Sleeve (pc# 10).
11. Remove the upper Thrust Ball Bearing (pc# 4) from the Housing (pc# 1).
12. Remove the Idle gear (pc# 7) from the Housing (pc# 1).
13. Separately, remove the Helical Gear (pc# 8) from the Idle gear (pc# 7) by removing Snap ring (pc# 9).
14. Remove the Helical Pinion subassembly from the Housing (pc# 1).

Reassembly Instructions

Refer to Figure 5.2

1. Place the Housing (pc# 1) upside down for internal access.
 2. Install the O-Ring (pc# 3) in the Housing (pc# 1).
- NOTE:** Lubricate all O-Rings before installation
3. Install the upper Thrust Ball Bearing (pc# 4) in the Housing (pc# 1).
 4. Separately, install the Helical Gear (pc# 11) onto the Drive Sleeve (pc# 10), engaging the Helical Gear and Drive Sleeve lugs.
 5. Install the assembled Helical Gear (pc# 11) and Drive Sleeve (pc# 10) into the Housing (pc# 1) and upper Thrust Ball Bearing (pc# 4).
 6. Install the lower Thrust Ball Bearing (pc# 15) onto the Drive Sleeve (pc# 10).

Sambo SB-SR series spur gear

7. Install the Bearing (pc# 13 and pc# 5) at Housing and Base.
8. Install the Idle gear (pc# 7) and Helical gear (pc# 8) after That put Snap ring (pc# 9)
9. Install the Helical Pinion (pc# 12) subassembly into the Housing (pc# 1).
10. Replace the Oil Seal (pc# 2 and pc# 33) in the Input Flange (pc# 32), if required.
11. Place the Gasket (pc# 16) onto the Housing (pc# 1).
13. Install the Base (pc# 17) onto the Housing (pc# 1) and Drive Sleeve (pc# 10) using Socket Head Cap Screws (pc# 19).
13. Install the Thrust Housing (pc# 21) with O-Ring (pc# 22) onto the Base (pc# 17) using Socket Head Cap Screws (pc# 24).
- a CAUTION:** Care must be taken to ensure that the O-ring located in the Thrust Base is not damaged during installation.
14. Install the upper Thrust Roller Bearing (pc# 25) into the Thrust Housing (pc# 21).
15. Install the Stem Nut (pc# 26) into the Thrust Housing (pc# 21) and upper Thrust Roller Bearing (pc# 25).
16. Install the lower Thrust Roller Bearing (pc# 27) onto the Stem Nut (pc# 26).
17. Place the Gasket (pc# 28) onto the Thrust Base (pc# 30).
18. Separately, install the O-Ring (pc# 29) into the Thrust Base (pc# 30).
19. Install the Thrust Base (pc# 31) with O-Ring (pc# 15) onto the Thrust Housing (pc# 2) and Stem Nut (pc# 5) using Socket Head Cap Screws (pc# 34).
- a CAUTION:** Care must be taken to ensure that the O-ring located in the Thrust Base is not damaged during installation.
20. Place the gearbox in the upright position.
21. Install the Stem Cover Adapter (pc# 38) and O-Rings (pc# 39 and pc# 40) on the Housing (pc# 1).
22. Replace the Oil Seal (pc# 43) in the Input Flange (pc# 42), if required.
23. Replace the Oil Seal (pc# 2) onto the Housing (pc# 1) and install the Input Flange (pc# 42) using Socket Head Cap Screws (pc# 44)

a CAUTION: For proper backlash of the Helical gear set, ensure supplied gaskets and shims (if applicable) are placed between Base and Housing.

NOTE: Ensure binding does not occur between the Helical Pinion and Helical Gear

NOTE: Lubricate all Oil Seals before installation

Sambo SB-SR series spur gear

Figure 5.2 - SR200H,300H,400H,500H,600H,700H- SR800H Assembly View

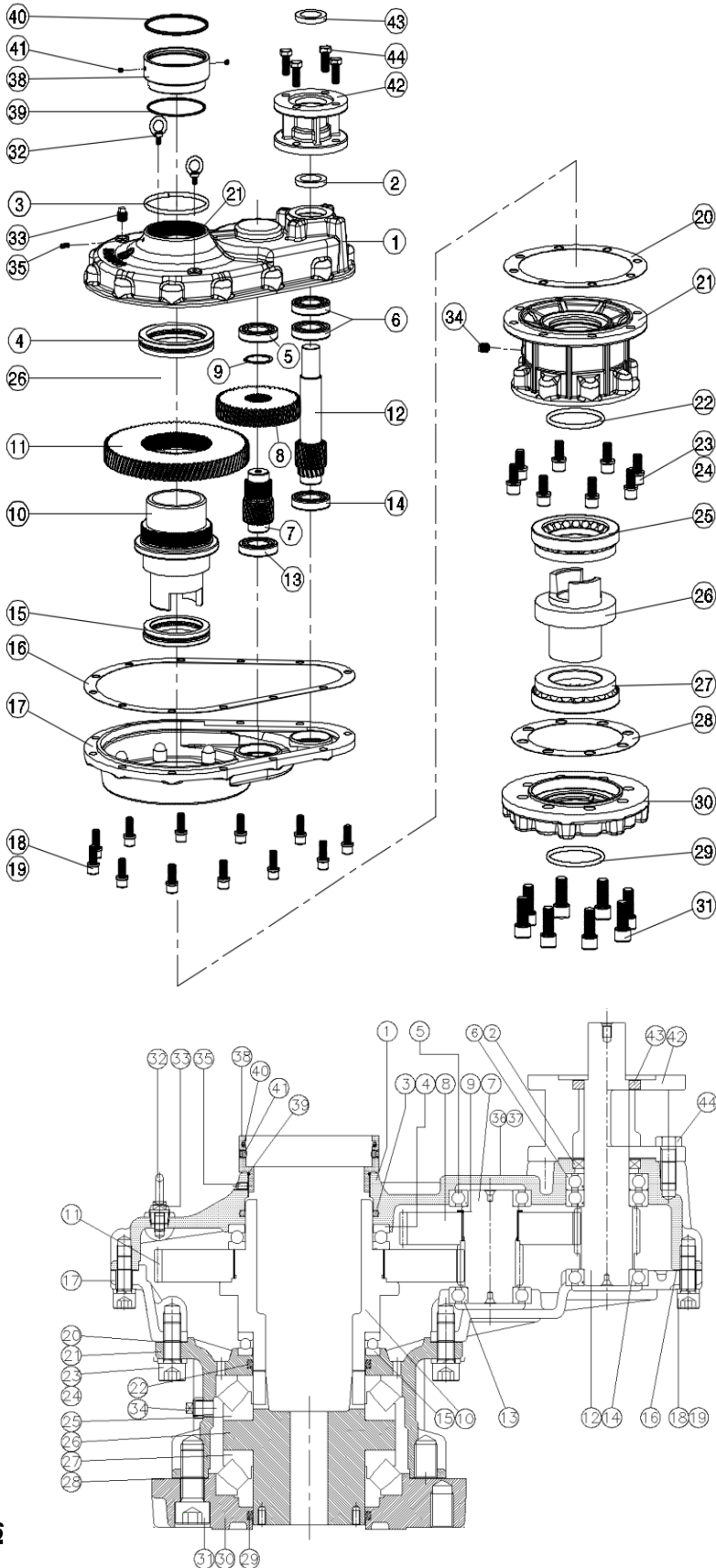

Table 5.2 – SR200H Through SR800H Parts List

Item No.	Description	REMARK
1	HOUSING	
2	OIL SEAL	
3	ORING for HOUSING	
4	THRUST BALL B/R	
5	BALL BEARING for IDLE GEAR	
6	BALL BEARING for HELICLA PNION	
7	IDLE GEAR	
8	S-HELICAL GEAR	
9	SNAP RING	
10	SLEEVE	
11	M-HELICAL GEAR	
12	HELICAL PINION	
13	BALL BEARING for IDLE GEAR	
14	BALL BEARING for HELICLA PINION	
15	THRUST BALL B/R	
16	GASKET for BASE	
17	BASE	
18	WASHER_SPRING	
19	WRENCH BOLT	
20	GASKET for THRUST HOUSING	
21	THRUST HOUSING	
22	ORING for THRUST HOSING	
23	WASHER_SPRING	
24	WRENCH BOLT	
25	THRUST ROLLER BEARING	
26	STEM BUSH	
27	THRUST ROLLER BEARING	
28	GASKET for THRUT BASE	
29	ORING for THRUST BASE	
30	THRUST BASE	
31	WRENCH BOLT	
32	EYE BOLT	
33	PLUG SQ-HEAD	
34	PLUG SQ-HEAD	
35	SET SCREW	
36	NAME PLATE	
37	RIVET	
38	PF ADAPTER	
39	ORING	
40	ORING	
41	SET SCREW	
42	M.O.V. FLANGE	
43	OIL SEAL	
44	HEX BOLT	

